

800/1100ML DISPENSER MOUNTING INSTRUCTIONS

READ COMPLETE INSTRUCTIONS PRIOR TO INSTALLATION

TAPE MOUNTING

- Extreme caution must be exercised to insure mounting surface is flat, free of imperfections, clean and dry.
Tape mounting is only recommended for mirrors or other similar flat surfaces without imperfections. Clean flat surface with supplied towelette, or other surfaces with an abrasive cleanser prior to using towelette (depending on surface condition). Dry surface thoroughly.
- Remove protective backing from tape as shown and firmly press dispenser against the mounting surface for 10 seconds. Open cover and press directly on back plate for an additional 10 seconds. Allow 8 hours before loading unit.
- Opening instructions - push up on the two release buttons on each side of the base with the thumb and forefinger. With the other hand, gently pull the cover away from the wall at the top of the dispenser. For locking units, insert provided key into keyhole in the right-hand release button and press upward; the key must remain in the keyhole while closing the dispenser.

screw mounting holes (5)

tape

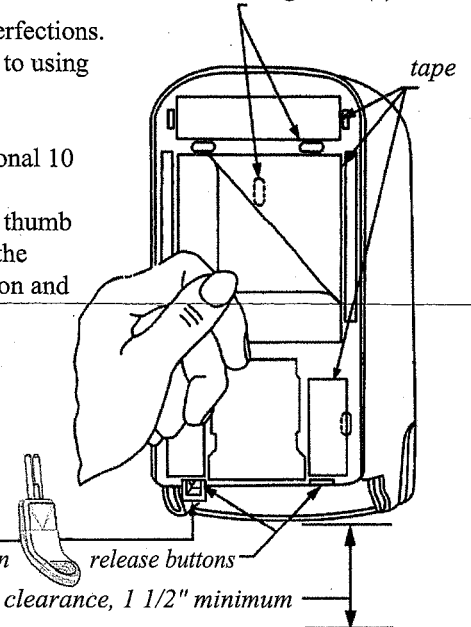

SCREW MOUNTING

- Recommended for surfaces that do not meet the standards set forth for Tape Mounting in the section above.
- Hold dispenser against wall in desired position, open cover and mark screw hole location on wall, insuring that screw heads will not interfere with release bar.
- Use appropriate anchors and drill size for #10 x 1" self-taping screws to attach dispenser firmly to the wall.

SOAP INSTALLATION INSTRUCTIONS

PLACE THE CARTRIDGE ON THE DISPENSER PLATFORM. PULL THE NOZZLE DOWN AND WITH THE THUMB AND FOREFINGER. ROTATE THE TOP OF THE TUBE SO THAT THE **ARC OF THE HALF MOON** PORTION OF THE PUMP IS FACING TOWARD YOU.

ARC OF THE HALF MOON PUMP

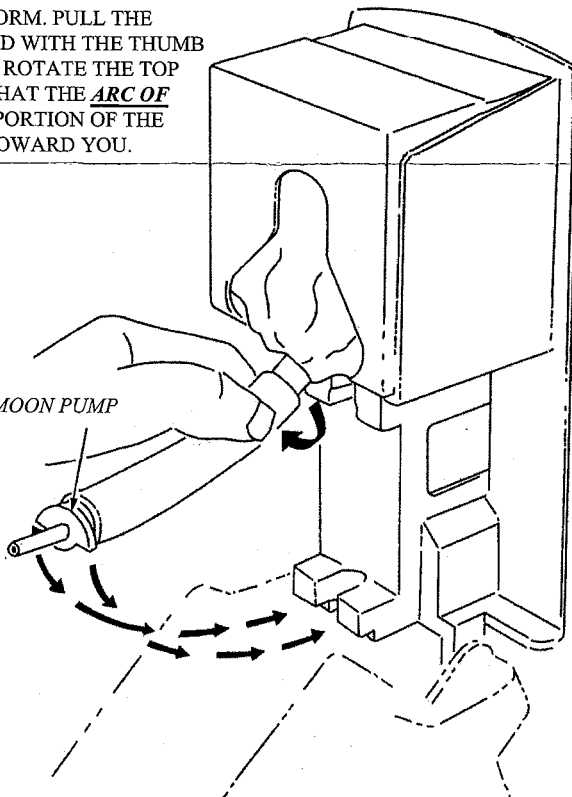

THEN PLACE THE TOP OF THE TUBE FIRMLY IN THE NECK OF THE UPPER LOCATOR AND FIT THE EARS OF THE HALF MOON PUMP IN THE SLOTS IN THE LOWER LOCATOR.

UPPER LOCATOR

EARS OF THE HALF MOON PUMP

LOWER LOCATOR SLOTS

BEFORE CLOSING THE COVER, CHECK TO MAKE SURE THE **ARC OF THE HALF MOON PUMP** IS FACING TOWARD YOU AND THE **EARS OF THE HALF MOON PUMP** ARE FIRMLY SEATED IN THE SLOTS OF THE LOWER LOCATOR.

